



---

## Supplier Manual

---

## Table of Contents

<a href="#"><u>Supplier Qualification</u></a> .....	3
<a href="#"><u>Corporate Responsibility</u></a> .....	3
<a href="#"><u>Policy On Business Gifts</u></a> .....	4
<a href="#"><u>Grievance Process</u></a> .....	4
<a href="#"><u>Conflict Materials</u></a> .....	5
<a href="#"><u>IMDS Requirements</u></a> .....	5
<a href="#"><u>Certificate of Analysis</u></a> .....	6
<a href="#"><u>Special Processes</u></a> .....	6
<a href="#"><u>Supplier Schedules</u></a> .....	7
<a href="#"><u>Contingency Plan</u></a> .....	7
<a href="#"><u>Supplier Shipping Policy</u></a> .....	8
<a href="#"><u>Receiving Requirements</u></a> .....	8
<a href="#"><u>Labeling and Bar Code Requirements</u></a> .....	9
<a href="#"><u>Invoicing Requirements</u></a> .....	13
<a href="#"><u>NC/Corrective Action Information</u></a> .....	13
<a href="#"><u>Cost Recovery Information</u></a> .....	14
<a href="#"><u>Supplier Performance Measurements</u></a> .....	15
<a href="#"><u>Noble Polymers Supplier Rating</u></a> .....	20

## Supplier Qualification

---

Qualification/Development of all Noble Polymers Direct Material Suppliers

### Process Steps

- Prior to any exchange of intellectual property it will be necessary to have a signed Supplier CDA (Confidential Disclosure Agreement)
- **Supplier Information Form** is filled out by potential supplier (on Noble Polymers Website <http://www.noblepolymers.com/supplier-information>) and submitted to Purchasing
- Noble Polymers purchases under Noble Polymers' Terms & Conditions (on Noble Polymers Website <http://www.noblepolymers.com/terms-warranties>)
- Quality, Diversity, Environmental, and any other Certifications are submitted by supplier to Purchasing. (NOTE: Any reference to a quality or environmental certification must be to the current certification version.) Quality certifications must be with Registrars accredited through the IAF MLA and IATF.)
- A Dunn & Bradstreet Report may be generated
- A Master Supplier Agreement may be initiated
- On-site audits/visits are scheduled as necessary
- An onsite audit may be required

### Evaluation

- Commodity Manager & Sr. Director Supply Management make the qualification decision whether or not to add a supplier

## Corporate Responsibility (Supplier Code of Conduct)

---

Corporate Responsibility is the ongoing commitment by business to act ethically and contribute to economic development while improving the quality of life of the workforce and their families as well as of the local community and society at large. Noble Polymers supports our suppliers to follow the AIAG Corporate Responsibility Guidance Statement that can be found at [www.aiag.org](http://www.aiag.org) under Corporate Responsibility. All suppliers are required to complete *AIAG Supply Chain Sustainability eLearning* that can be found at [www.aiag.org](http://www.aiag.org). This is a no-cost training session.

## Policy on Business Gifts

Noble Polymers associates may not solicit any gift, entertainment or other gratuity. Noble Polymers may not accept gifts, entertainment, or other gratuities from anyone seeking a contract with or purchase by Noble Polymers other than customary business courtesies that are reasonable in frequency and valued at \$100 or less. Any business gift or item of value greater than \$100 must be approved in writing by the Sr. Director Supply Management prior to acceptance.

## Grievance Process

Noble Polymers feels interaction with our Suppliers is very important and always wants to preserve relationships with our supply base. With that intent in mind, the following process should be used whenever a supplier feels they have a grievance or concern. Any questions may also be sent in writing to the Sr. Director of Supply Management if going through the process does not seem appropriate.

<i>Type of Issue</i>	<i>Order of Escalation</i>			
<b>Delivery</b>	Materials	Materials Manager	Plant Manager	Purchasing Commodity Lead
<b>Supplier Quality</b>	Plant Quality Engineer	Quality Mgr. / Supplier Quality Mgr.	Plant Manager	Purchasing Commodity Lead
<b>Commercial</b>	Purchasing Commodity Lead	Sr. Commodity Manager	Sr. Director Supply Management	VP of Operations
<b>Ethical</b>	Sr. Commodity Manager	Sr. Director Supply Management	VP of Operations	Sr. VP of Department of Business Services
<b>Supplier Performance</b>	Sr. Purchasing Specialist	Purchasing Commodity Lead	Sr. Commodity Manager	Sr. Director Supply Management

## Conflict Materials

---

### Background

In August 2012, the U.S. Securities and Exchange Commission adopted final rules to implement reporting and disclosure requirements related to “Conflict Minerals,” as directed by the Dodd-Frank Wall Street Reform and Consumer Protection Act of 2010. Publicly traded U.S. companies that make products in which 3TG metals (tantalum, tin, tungsten and gold) are necessary to product functionality or production are required to assess their supply chains and publically report on whether those materials are sourced from countries in and around the Democratic Republic of Congo (the “Conflict Region”).

### Position

Noble Polymers supports efforts to end human rights abuses wherever they may occur, and acts in accordance with our vision of respecting global communities. We conduct business in a manner intended to avoid intentionally or knowingly contributing to such abuses. At Noble Polymers we strive to uphold one consistent standard of ethical conduct on a global basis, while respecting the culture and business practices of every country and community we touch. In the global business environment in which we operate, our long-term success is dependent on each of us executing business decisions with the highest ethical standards. Consistent with this commitment, our objective is to use conflict free materials and components in manufacturing our products. We expect our global supply chain partners to do the same, whether or not they are subject to the regulations on “Conflict Minerals.”

The reporting of Conflict Materials will be ongoing. Our expectation is that you notify us anytime a new component is purchased that requires a new Conflict Materials assessment. We will send you a new survey to complete.

## IMDS Requirements

---

Noble Polymers, in support of our customers’ requirements, participates with the International Material Data System (IMDS). IMDS is a global data bank that contains information on materials used by the automotive and heavy truck industries. This is an international endeavor to better track and report the material content of manufactured products.

In support of this effort, Noble Polymers must report all materials present in finished products. These are collected, evaluated, and stored in the IMDS system. IMDS helps the suppliers to meet the regulatory requirements placed on manufacturers and to comply with global regulations and environmental laws.

Noble Polymers may require IMDS as a part of the supplier PPAP submission. This will include a chemical composition breakdown for raw materials (this data can be retrieved from the material certs) for all components supplied.

- If you have not already established a user ID for IMDS, please go to the following website:  
[www.mdssystem.com](http://www.mdssystem.com)
- You will also want to check your material certifications for restricted chemical substances on  
[www.gadsl.org](http://www.gadsl.org)
- Noble Polymers does not offer training to its suppliers, however, commercial training is available on  
[www.mdssystem.com](http://www.mdssystem.com)
- You must enter the appropriate Client ID # for IMDS to automatically route your completed forms to the IMDS Client Manager. Use the following Client ID # for Noble Polymers:
  - Client ID # 51182

## Certificate of Analysis

---

Noble Polymers requires Certificate of Analysis when required by our customers. C of A's must be submitted to the respective locations prior to the delivery of materials.

- [noblecoa@noblepolymers.com](mailto:noblecoa@noblepolymers.com) for Noble Polymers

## Special Processes

---

All parts undergoing a special process, whether purchased or treated at your facility, must be identified to Noble Polymers. Those special processes are defined here.

Heat Treating – CQI-9	Coating – CQI-12	Plastic Molding – CQI-23
Plating – CQI-11	Solder – CQI-17	Casting – CQI-27

An applicable AIAG CQI form must be completed for all parts being utilized in automotive applications, or as directed by the Customer.

## Supplier Schedules

---

Supplier requirements will be communicated through Supplier Schedule/Material Releases, Purchase Orders, inventory levels, or Kanban. Requirements can be retrieved through EDI, portal or email. Materials will work with each supplier to communicate what method will be used. Electronic methods are always preferred.

Contained on the Purchase Order or Supplier Schedule/Material Release is the following information:

- Your company name, address, and Noble Polymers assigned supplier number
- Your company contact information (if information is incorrect it is the suppliers' responsibility to call with corrections)
- Noble Polymers' right to inspect
- Release ID (Noble Polymers assigned, date of release update)
- Purchase Order number – must be on all shipping and invoicing documents
- Part number and description – must be on all boxes and documents
- Delivery dates (**in house at Noble Polymers**) and quantity information

Noble Polymers expects suppliers to utilize a robust capacity planning process. If there is a period of two continuous weeks or more where Noble Polymers' needs push the supplier's capacity utilization to 120%, we would like to be notified. That notification should include the supplier's plan to manage the short and long term capacity constraint.

If there is a period of four continuous weeks where Noble Polymers' needs push the supplier's capacity utilization to 100%, we would like notification and a capacity plan constraint communicated.

Please note that, notwithstanding anything contained in any purchase order, statement of work or other communication from Noble Polymers, volumes and the duration of awarded programs are dependent on customer demand and are not guaranteed by Noble Polymers. Quantities listed as estimates by Buyers are best estimates of the quantities of supplies required and are subject to change from time to time, without r without notice to Seller and shall not be binding upon the Buyer. Unless otherwise expressly stated in the Order, Buyer makes no representation, warranty, guaranty or commitment of any kind or nature, whether express or implied, to Seller in respect of Buyer's quantitative requirements for the supplies or the term of supply of the supplies.

## Contingency Plan

---

Noble Polymers requires suppliers to have contingency plans in place that will ensure uninterrupted flow of products and services. These need to be available upon request to Noble Polymers. They need to address the following criteria:

- Key equipment failures
- Interruption from externally provided products, processes and services
- Recurring natural disasters
- Utility interruptions
- Labor shortages
- Infrastructure disruptions
- Cyber attacks
- Validate that the manufactured product continues to meet customer specifications after the re-start of production following an emergency in which production was stopped and if the regular shutdown processes were not followed.

## Supplier Shipping Policy

---

Please be advised that if you fail to ship parts according to the releases, it is your responsibility to immediately notify your Noble Polymers contact. By doing this, Noble Polymers may be able to work with you and address your inability to ship the correct quantity on time.

The logistics routing guide can be found at <http://www.noblepolymers.com/routing-guide>.

If you do not contact us before your shipping date and you do not ship the correct parts in the correct quantity with the correct paperwork, we reserve the right (in addition to other remedies that may be available) to immediately issue a non-conformance or corrective action. If, as a result of a non-conformance, our plant(s) experiences downtime or our customers are affected, we may immediately engage in cost recovery efforts.

Your compliance to this policy will help prevent jeopardizing our customers due to outages and/or incorrect product.

It is **your responsibility** to contact us if you are not seeing updated releases. If there is a system problem, we can address the situation and make the necessary corrections.

## Receiving Requirements

---

Noble Polymers requires the following to ensure on time receiving:

1.	Complete Bill of Lading / Packing Slip (or both if required) to include the following:		
	Destination Address	Bill of Lading Number	Noble Polymers' Part Number
	Supplier Name	Actual Ship Quantity	Lot Number(s) – if applicable



	Delivery Date	Part Description	Noble Polymers Purchase Order Number
2.	Bar Code Label on all cartons		
3.	Advanced Shipping Notification (ASN) as available		

**Lack of proper paperwork can have the following effects:**

- **Product may be refused**
- **Payment can be delayed**
- **Receiving is difficult and can be delayed**
- **Production could be jeopardized**
- **An NC may be issued**
- **Performance score may be affected**

## Labeling and Bar Code Requirements













All incoming product shall have bar code labels that are readable by Noble Polymers. Standard 4 x 6 AIAG label format. When using a standard barcode app, Code 39 or Code 128 should be used depending on the length of the part number. (Code 128 works better for longer part numbers.) Code 39 is sometimes referred to as Code 3 of 9. See Examples.

All incoming product must be labeled with the following:

- 1) Two or Four Product Labels per carton. See below.
- 2) One Master Label per SKU on skid.
- 3) Noble Polymers part number, quantity, and purchase order number must be a print size of 1/2”.

Product Label Details		
1	Noble Polymers part number	Barcode (P) prefix
2	Part Description	Non-Barcode
3	Quantity	Barcode (Q) prefix
4	Noble Polymers purchase order number	Barcode (K) prefix
5	Inspection status	Leave blank if not inspecting
6	Lot number or serial number (if applicable)	Barcode (S or 1T) prefix
7	Tare Weight (optional)	Non-Barcode
8	Labels should be on 2 adjacent corners of the box at a minimum for a box 24” or smaller	
9	Boxes/Gaylords larger than 24” on a side must have 4 labels (one on each side)	
10	Boxes on a skid should have labels facing out on all 4 sides of skid	

In the case of returnable containers, all previous stickers must be removed or blocked out. Labels need to be on adjacent corners. It is the supplier's responsibility to notify Noble Polymers of packaging that needs repair, re-work or disposal.

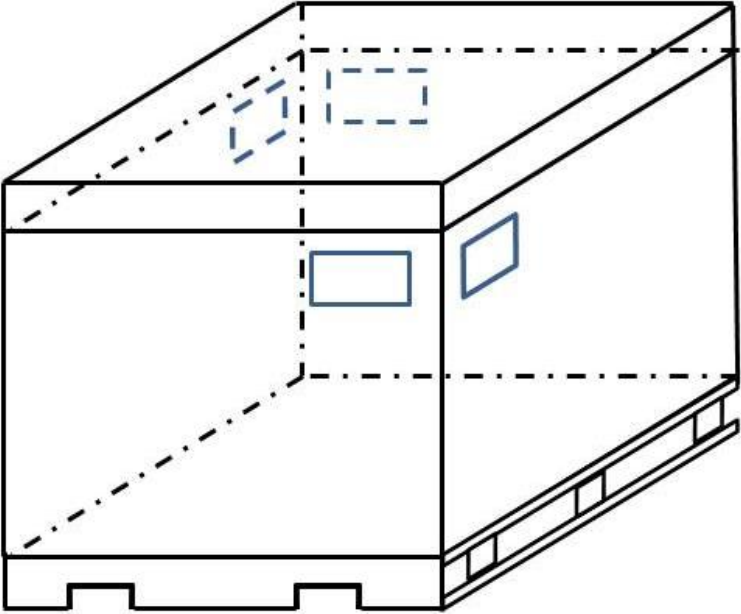
<p><b>Lot # Label Example</b></p>	<table border="1" data-bbox="506 438 1318 974"> <tr> <td data-bbox="553 491 857 533">           PART NO. (P) <b>5000-P759</b> </td> <td data-bbox="1036 491 1219 562">           INSPECTION STATUS <b>OK TO USE</b> </td> </tr> <tr> <td data-bbox="630 525 935 590">  </td> <td></td> </tr> <tr> <td data-bbox="553 596 857 688">           DESCRIPTION <b>WHITE PE MB WHITE PE MB</b> </td> <td data-bbox="1036 596 1183 659">           MANUFACTURED <b>3/10/2010</b> </td> </tr> <tr> <td data-bbox="553 695 764 737">           LOT NO. (IT) <b>12345</b> </td> <td data-bbox="1036 695 1146 758">           TARE WEIGHT <b>52 LBS</b> </td> </tr> <tr> <td data-bbox="630 730 850 798">  </td> <td></td> </tr> <tr> <td data-bbox="553 804 753 846">           QUANTITY (Q) <b>1700</b> </td> <td data-bbox="873 804 1122 846">           PO NO. (K) <b>AGS10991</b> </td> </tr> <tr> <td data-bbox="630 842 802 909">  </td> <td data-bbox="927 842 1179 909">  </td> </tr> <tr> <td colspan="2" data-bbox="574 919 967 940">           Supplier Name, 1234 Maint Street, Grand Rapids, MI 49512         </td> </tr> </table>	PART NO. (P) <b>5000-P759</b>	INSPECTION STATUS <b>OK TO USE</b>			DESCRIPTION <b>WHITE PE MB WHITE PE MB</b>	MANUFACTURED <b>3/10/2010</b>	LOT NO. (IT) <b>12345</b>	TARE WEIGHT <b>52 LBS</b>			QUANTITY (Q) <b>1700</b>	PO NO. (K) <b>AGS10991</b>			Supplier Name, 1234 Maint Street, Grand Rapids, MI 49512	
PART NO. (P) <b>5000-P759</b>	INSPECTION STATUS <b>OK TO USE</b>																
																	
DESCRIPTION <b>WHITE PE MB WHITE PE MB</b>	MANUFACTURED <b>3/10/2010</b>																
LOT NO. (IT) <b>12345</b>	TARE WEIGHT <b>52 LBS</b>																
																	
QUANTITY (Q) <b>1700</b>	PO NO. (K) <b>AGS10991</b>																
																	
Supplier Name, 1234 Maint Street, Grand Rapids, MI 49512																	
<p><b>Product Label Placement Example</b></p>	 <p>The diagram shows a 3D perspective of a rectangular container on a pallet. Dashed lines indicate the internal structure and the placement of labels on adjacent corners of the container's front and side panels.</p>																

Master Label Details		
1	Noble Polymers part number	Barcode (P) prefix
2	Part Description	Non-Barcode
3	Quantity	Barcode (Q) prefix
4	Noble Polymers purchase order number	Barcode (K) prefix

**Master Label Example**

**MASTER LABEL**

---



PART NO (P) **5000-P759**



---

DESCRIPTION **WHITE PE MB**  
**WHITE PE MB**

---

QUANTITY (Q) <b>1700</b> 	PO NO (K) <b>AGS10991</b> 
---	---

Supplier Name, 1234 Maint Street, Grand Rapids, MI 49512

**Master Label Placement Example**

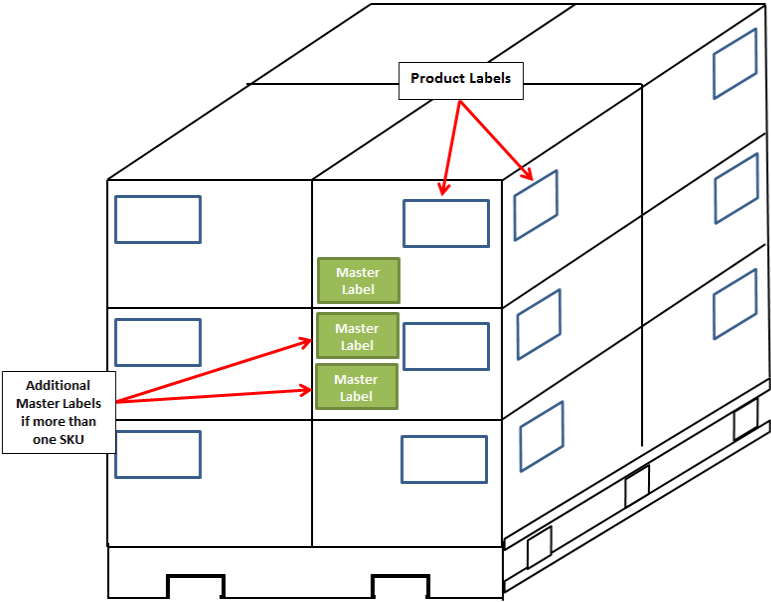

## Engineering and PPAP Samples

Engineering samples provided to Noble Polymers must be labeled clearly on the package and parts with the following guidelines:

- 3 x 5 inch yellow label
- Affix to front and back of each package
- Include the following on the label:
  - SAMPLE MATERIAL or PPAP SAMPLE
  - ATTN: \_\_\_\_\_
- Actual sized sample labels displayed below:

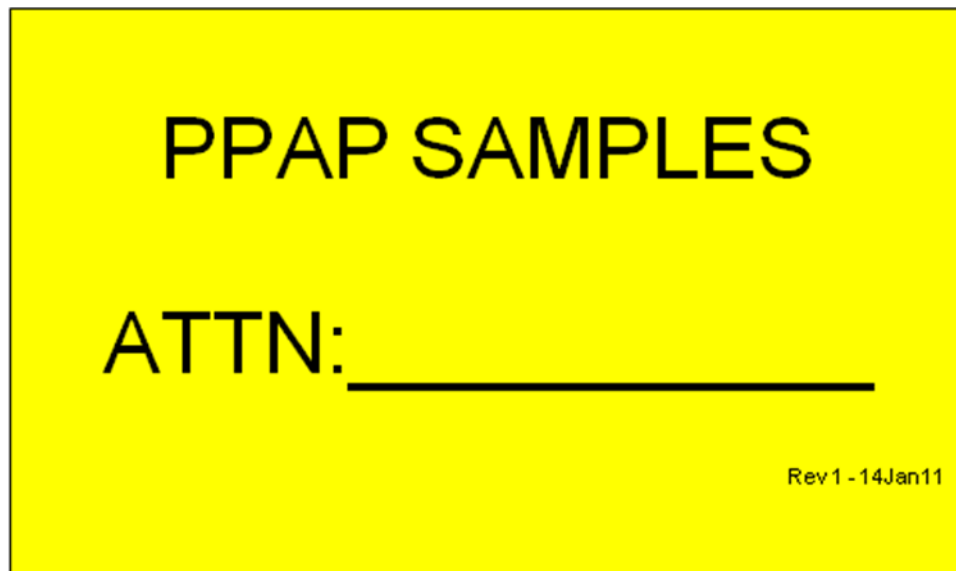
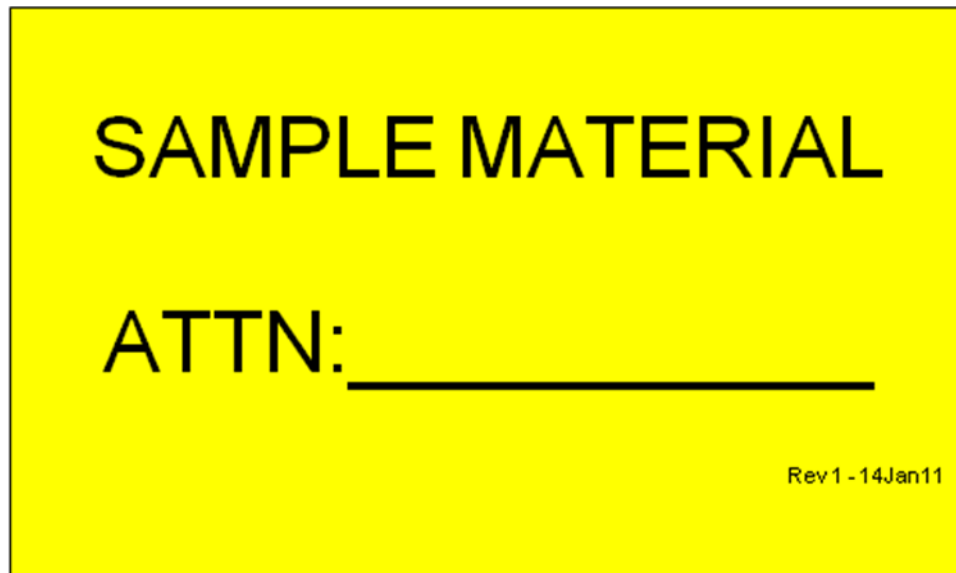

## Invoicing Requirements

---

All invoices must include the following information:

1. Noble Polymers part number
2. Noble Polymers purchase order number
3. Quantity shipped
4. Price
5. Packing slip / BOL number

**Any non-conforming invoices will be returned unprocessed.**

Noble Polymers standard payment terms are net 60.

All invoices are to be sent to:

[cepayables@cascadeng.com](mailto:cepayables@cascadeng.com)

## NC/Corrective Action Information

---

An NC, 3L5Why or corrective action is initiated to a supplier when it is determined that it is necessary to formally address a problem (not all problems will require a corrective action, 3L5Why or NC). The severity of the problem will determine the response required. A 2<sup>nd</sup> Party audit may be conducted as a result of a corrective action. The audit scope will be defined and provided to the auditee prior to the audit.

- Initial response must be given within 24 hours and must include:
  - Problem confirmation and results of inventory review at supplier location if containment is required.
  - Brief description of containment plan and implementation timing (if required)
- RMA issued:
  - RMA number must be issued within 5 working days
- Final response must be given within 10 working days and must include:
  - Root cause of the problem and method used for discovery and verification
  - Corrective and preventative actions and implementation dates
  - Completed 3L5Why (if required)
- Rework and disposition will be coordinated by the plant Quality Engineer or designee. Delivery issues will be coordinated with Materials.

## Cost Recovery Information

---

**General Costs** – A \$150 charge may be assessed for each NC, 3L5Why or corrective action issued.

**Rework / Containment Costs** – Should a problem be detected with your product you will be given the option to come into Noble Polymers and sort the product yourself, send in an independent sort company, or have product returned and replaced at your expense. The freight expense is considered premium shipment costs. Noble Polymers will charge you **\$75 per hour** per person for rework until your choice of options has arrived to correct the problem.

**Errors in Production Documentation (missing cert, mislabeled cartons, etc.)** – Any shipment that arrives without required documentation or with incorrect information, may be refused at our option. If this refusal results in a shutdown, shutdown charges (below) will be assessed.

**Shut down Costs** – In the event that a Noble Polymers press is shut down due to non-receipt of product or receipt of defective product, an hourly charge equal to the rate per hour of that press will be charged to the supplier until the press is back up and running. **Hourly press rates range from \$150 per hour to \$750 per hour depending on press size and labor required.**

Unless covered by the number of tryouts quoted on the tooling RFQ, the tool supplier will be responsible for additional costs associated with production downtime for the issues that are the responsibility of the supplier. The costs will be applied as stated above.

**Customer Rejects** – Noble Polymers will recover all customer charges as they relate to supplier quality defects/rejects along with any charges Noble Polymers incurs for overtime.

**Premium Shipment Costs** – If you incur any premium shipment costs, a copy of the invoice must be sent to Noble Polymers, Attention Logistics Department. All premium freight costs must be tracked per Quality requirements. Please include an explanation of the expense.

**Excessive Problem Solving Costs** – If a supplier issue requires extended use of Noble Polymers salaried resources in order to close out the issue, the supplier will be notified and asked to provide on-site support for the duration of the issue or will be charged for the use of Noble Polymers' resources. **Hourly rates for salaried and engineering resources will be charged at a rate of \$75 per hour.**

**Travel Costs** – Travel time and expenses of Noble Polymers employees (hourly and salaried) required for support (plant visits, customer updates necessary at the customer location, etc.) of supplier issues may be charged back to the supplier.

**Other Remedies** – The foregoing will not limit any of the other rights or remedies that may be available to Noble Polymers under the parties' contract or applicable law.

## Supplier Performance Measurements

Suppliers delivering/servicing production materials regularly will be measured on the following criteria.

Sections	Value
Delivery	20 Points
Quality	30 Points
Disruptions	30 Points
Value	15 Points
Management System	5 Points

**Delivery:** **Requirement: 100% on time delivery 20 points**

**Dates on supplier schedules/purchase orders are “in house” dates.** Suppliers may be allowed to ship up to 2 days early. This will be discussed on a per item basis. Late deliveries will be counted against the total score. (Exceptions will only be considered if arrangements are made prior to the due date and do not jeopardize our customer schedules.)

- A. Quantity – Received quantity must equal Noble Polymers order release quantity.
  - a. Under shipments and late deliveries may result in a 5 point deduction
  - b. Over-shipment and shipments arriving more than 2 days early may result in a 2 point deduction
  
- B. All shipments must contain a Bill of Lading/Packing Slip. Non-conforming paperwork may result in a point deduction. All Bill of Ladings/Packing Slips must comply with the requirements listed in the *Receiving Requirements* section.
  
- C. Premium Freight – Must be tracked and reported to Noble Polymers. Points may be deducted if premium freight is utilized. If premium freight is caused by Noble Polymers’ actions, premium freight will be tracked, but no point deduction will follow.

**Quality:** **Requirement: 100% quality product 30 points**

All incoming product must meet applicable specifications. “Applicable specifications” refers to the specifications that are approved during the latest PPAP. Before shipment starts, a Level 3 PPAP following the current AIAG manual must be submitted and approved for all new products unless otherwise defined by the Quality Engineer. Any changes to product must be re-submitted and approved prior to production/service

changes, **including but not limited to changes in suppliers, materials, processes, tooling, inspection criteria, or manufacturing facility.** If any change is initiated without approval, all costs, including but not limited to rejections, warranties and sorting, will be the responsibility of the supplier. Product that is received out-of-spec will be considered late. Line accumulations will be charged back once per month or more often if needed.

**Defective or out of spec materials**

The supplier is responsible for monitoring and managing the quality of their products.

- Noble Polymers does **not** perform receiving inspection
- If a supplier ships, or suspects they may have shipped, defective material to Noble Polymers or its customers, they are required to notify Noble Polymers immediately in writing and implement containment activities

PPM Results		
PPM =	$\frac{\text{Total Actual Verified Defective Parts}}{\text{Total Number of Received Parts}}$	X 1,000,000
Delivery PPM Performance		Point Value
0 PPMs		30 Points
1 – 125 PPMs		25 Points
126 – 249 PPMs		15 Points
250 – 1,000 PPMs		10 Points
1,001 – 2,000 PPMs		5 Points
2,001 +		0 Points

**Disruptions:** **Requirement: No disruption costs 30 points**

Disruptions are events that affect service to Noble Polymers’ manufacturing plant or customer’s plant. These types of events are listed below. The maximum point loss in this category is -30 points. All suppliers will be given 30 points to start the period. Deductions may be taken for disruptions.

Disruption Type	Point Value
Repeat delivery issue	10 Points
Repeat quality issue	10 Points



Customer claim	10 Points
Poor communication causing a disruption	10 Points
Late delivery causing CE FoC or Customer shutdown	10 Points
Late PPAP	10 Points
CPR (Configurable Problem Report) initiated	5 Points
Late CPR response	5 Points
Missed ASN	5 Points
Documentation error	5 Points
Defective Barcode	5 Points
Supplier expense premium freight	2 Points
Deviation request	2 Points
Opening an NC (Non-conformance)	2 Points

**Value: Goal: Products & Services that create a world class supply chain 15 points**

<b>Cost Reductions</b>	
<p><b>Innovation</b> – Noble Polymers has a 45 year history of developing innovative products, processes and materials. We believe that innovation can come from anyone, anywhere, at any time. We encourage all of our suppliers to exchange ideas with us in an effort to provide creative solutions that ultimately deliver better product, processes or material solution at the lowest total cost.</p> <p><b>VE/VA</b> – We believe that every product, process or material in use today can be improved. These improvements can be substantial or incremental but in both cases the end result is to make something better. As a current supplier to Noble Polymers, we value your capabilities and welcome your thoughts on how we can make things better together.</p>	
<b>Value</b>	<b>10 Points Possible</b>
<p>10 is the maximum points for this section while 0 is the minimum. Points will be awarded and/or deducted as follows:</p> <ul style="list-style-type: none"> <li>• This program will begin 9/2019 and continue as a rolling 12 months</li> <li>• 10 is the maximum points for this section</li> <li>• Points in this section will be reviewed quarterly</li> <li>• Cost savings proposals can earn up to 10 points</li> <li>• Implementation of a cost increase outside of signed agreements or unrelated to market movements deducts 10 points. It will apply for 12 rolling months or until a cost savings is implemented or a savings idea is proposed.</li> <li>• Holding costs for 12 months earns 7 of the 10 possible points</li> </ul>	

**DSS (Diversity/Safety/Sustainability)**

Noble Polymers is an Anti-Racist Company and strives to be a leader in diversity activities & programs internally, within our communities, and with our customers & suppliers. Noble Polymers tracks and measures our diverse spend against our goals. Noble Polymers also supports a Racism-Free supply chain and we ask our suppliers to do the same.

Noble Polymers values safety in everything that we do throughout our entire supply chain.

Noble Polymers focuses on sustainability as a part of everything we do.

We have created a question set to learn more about what your company is doing in the areas of Diversity, Safety, and Sustainability.

Points are allocated based on questions regarding your company practices or policies that have ‘Approved’ responses. Point valuation listed below.

NOTE: This assessment may be audited at your location.

Value	5 Points Possible
0 Approved	0 Points
1 – 3 Approved	1 Point
4 – 6 Approved	2 Points
7 – 9 Approved	3 Points
10 – 12 Approved	4 Points
13 – 15 Approved	5 Points

**Management Systems:**

**5 points**

Suppliers of direct (production) materials are expected to have an effectively implemented quality system.

All direct material suppliers for automotive production shall be third party registered by an accredited third-party certification body to ISO 9001 as a minimum with the ultimate objective of becoming certified to IATF automotive standard.

If a supplier is not certified to the ISO 9001 certification at a minimum, then said supplier would be allowed to supply product as long as one of the following criteria was met.

- Customer specifies we use the non-certified supplier (a customer sign off acknowledging this situation would be required).
- Noble Polymers conducts a second party audit to verify supplier’s compliance to ISO9001 requirements.
- Small Supplier Criteria - Decision criteria listed in Supplier Manual showing elements of ISO 9001 / IATF 16949 may be waived based on size of supplier. Noble Polymers does not currently have suppliers in this category of uncertified, small suppliers. When this need arises, criteria will be established.

All supplier for non-automotive production shall be third party registered by an accredited third-party certification body to ISO 9001 if required by Noble Polymers’ customer.

Exceptions must be approved by Noble Polymers or Noble Polymers’ customer if certification is required by the customer. For distribution companies, their suppliers that provide product for Noble Polymers must also comply with these requirements.

Noble Polymers expects all suppliers to have a system in place for management review of Key Performance Indicators. Information regarding the performance of these indicators shall be made available to Noble Polymers upon request.

Noble Polymers is committed to continuous reduction of negative impacts on the environment by utilizing an Environmental Management System. The support of suppliers throughout the supply chain is needed to meet this commitment. The point system is listed below.

<b>Quality Management System</b>	<b>4 Points Possible</b>
Registered to IATF 16949	4 Points
Registered to ISO 9001	3 Points
Not Registered	0 Points
<b>Environmental Management System</b>	<b>1 Point Possible</b>
Registered to ISO 14001	1 Point
Not Registered	0 Points

Maximum points available in this section are 5 points. If you are IATF 16949 and ISO 9001 certified, you would receive 4 points. NOTE: Your Registrar must be recognized by IATF (International Automotive Task Force).

In the event of revocation of registration, Noble Polymers must be notified within 48 hours. Submittal of new registration upon expiration of current is the supplier’s responsibility.

Noble Polymers reserves the right to perform a 2<sup>nd</sup> party audit to verify compliance. An audit may be used for supplier risk assessment, supplier monitoring, supplier QMS development, product audit, or process audits. A 2<sup>nd</sup> Party audit may be conducted as a result of a corrective action. The audit scope will be defined and provided to the auditee prior to the audit.

## Noble Polymers Supplier Rating

Point Range	Classification	Comments
95 – 100	Preferred	These suppliers will be first in line for new business opportunities in their commodity.
80 – 94	Acceptable	Suppliers in this category may still be awarded new business. While this rating is acceptable, suppliers should have a goal to improve and grow into the preferred supplier category.
70 – 79	Substandard	Suppliers with this rating for 3 or more consecutive months may be on new business hold. If this rating is achieved for 3 or more consecutive months, Supply Management may take one of the following actions: <ul style="list-style-type: none"> <li>- Meeting with supplier executive management</li> <li>- Formal CPR (Corrective Action)</li> <li>- Begin de-sourcing process</li> <li>- Schedule an on-site 2<sup>nd</sup> party Audit (Required for non-certified suppliers.)</li> </ul>
0 – 69	Probationary	Suppliers with this rating will be on new business hold. If this rating is achieved for 3 or more consecutive months, a complete formal corrective action will be requested to report how you are addressing your systemic failures. De-sourcing of the supplier may commence.

Supplier who fall below 70 points for six consecutive months may be de-sourced. The commodity manager will consider the following when making a determination to de-source.

- Customer-directed supplier
- Remaining life of program
- Level of difficulty in changing the supplier
- Sole source of product
- Total cost to change suppliers